

SC-80ML

METAL CORED ARC WELDING CONSUMABLE
FOR 550MPa CLASS HIGH TENSILE STEEL



❖ Specification

<i>AWS A5.36</i>	E80T15-M21A6-Ni1 H4
<i>AWS A5.36</i>	E80T15-M20A6-Ni1 H4
<i>(AWS A5.36M)</i>	E550T15-M21A6-Ni1 H4)
<i>(AWS A5.36M)</i>	E550T15-M20A6-Ni1 H4)
<i>(AWS A5.28)</i>	E80C-Ni1 H4)
<i>EN ISO 17632-A</i>	T 50 4 Z M M21 3 H5

❖ Applications

SC-80ML is used for welding in heavy equipment and bridge construction, structural fabrication

❖ Characteristics on Usage

SC-80ML is the metal cored wire which combines the high deposition rates of a flux cored wire with the high efficiencies of the solid wire.

SC-80ML provides an exceptionally smooth and stable arc, low spatter and minimal slag coverage and achieves good impact value to low temperature(-50°C).

❖ Note on Usage

1. Proper preheating(50~150°C) and interpass temperature must be used in order to release hydrogen which may cause cracking in weld metal when electrodes are used for medium and heavy plates
2. Use Ar + 10-25% CO₂ gas



Mechanical Properties & Chemical Composition of All Weld Metal

❖ Welding Conditions

Method by AWS Spec.

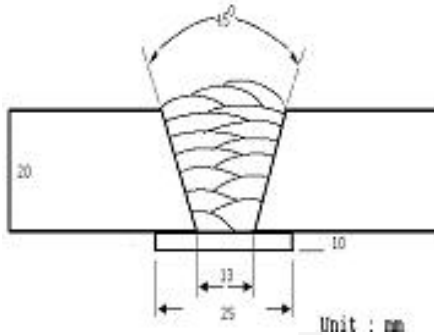

[Joint Preparation & Layer Details]

Welding Position	: 1G(PA)
Diameter	: 1.2mm (0.045in)
Shielding Gas	: 80%Ar + 20%CO ₂
Flow Rate	: 20 ℓ /min
Amp./ Volt.	: 280A/ 30V
Stick-Out	: 20~25mm (0.79~0.98in)
Pre-Heat	: R.T .
Interpass Temp.	: 150±15℃ (302±59°F)
Polarity	: DC(+)

❖ Mechanical Properties of all weld metal

Consumable	Tensile Test			CVN Impact Test J(ft · lbs)	
	YS Mpa(ksi)	TS Mpa(ksi)	EL (%)	-40℃ (-40°F)	-50℃ (-58°F)
SC-80ML	561(81)	627(91)	24.6	71(52)	60(44)
AWS A5.36 E80T15-M21A6	≥ 470 (68)	550~690 (80~100)	≥ 19	≥ 27J at -50℃ (≥ 20ft · lbs at -58°F)	

❖ Chemical Analysis of all weld metal(wt%)

Consumable	C	Si	Mn	P	S	Ni	Cr	Mo	V
SC-80ML	0.072	0.49	1.47	0.007	0.017	0.93	0.032	0.088	0.005
AWS A5.36 Ni1	≤ 0.12	≤ 0.80	≤ 1.75	≤ 0.03	≤ 0.03	0.80 ~1.10	≤ 0.15	≤ 0.35	≤ 0.05

This information is provided solely for the purpose of confirming product conformance with applicable standards. The serviceability of a product or structure utilizing this type of information is and must be the sole responsibility of the builder/user. Many variables beyond the control of HYUNDAI WELDING CO., LTD. affect the results obtained in applying this type of information. These variables include, but are not limited to, welding procedure, shielding gas, plate chemistry and temperature, weldment design, fabrication methods and service requirements.



Mechanical Properties & Chemical Composition of All Weld Metal

❖ **Welding Conditions**

Method by AWS Spec.

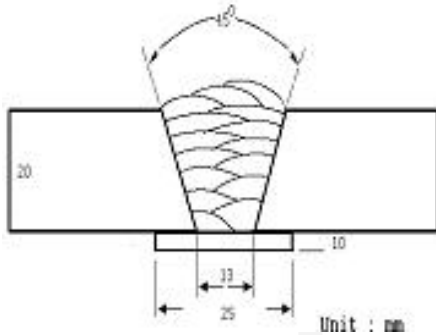

[Joint Preparation & Layer Details]

- Welding Position** : 1G(PA)
- Diameter** : 1.2mm (0.045in)
- Shielding Gas** : 90%Ar + 10%CO₂
- Flow Rate** : 20 ℓ /min
- Amp./ Volt.** : 280A/ 29V
- Stick-Out** : 20~25mm (0.79~0.98in)
- Pre-Heat** : R.T .
- Interpass Temp.** : 150±15℃ (302±59°F)
- Polarity** : DC(+)

❖ **Mechanical Properties of all weld metal**

Consumable	Tensile Test			CVN Impact Test J(ft · lbs)	
	YS Mpa(ksi)	TS Mpa(ksi)	EL (%)	-40℃ (-40°F)	-50℃ (-58°F)
SC-80ML	575(83)	639(92)	25.2	69(51)	63(46)
AWS A5.36 E80T15-M20A6	≥ 470 (68)	550~690 (80~100)	≥ 19	≥ 27J at -50℃ (≥ 20ft · lbs at -58°F)	

❖ **Chemical Analysis of all weld metal(wt%)**

Consumable	C	Si	Mn	P	S	Ni	Cr	Mo	V
SC-80ML	0.078	0.51	1.50	0.007	0.016	0.94	0.035	0.092	0.006
AWS A5.36 Ni1	≤ 0.12	≤ 0.80	≤ 1.75	≤ 0.03	≤ 0.03	0.80 ~1.10	≤ 0.15	≤ 0.35	≤ 0.05

This information is provided solely for the purpose of confirming product conformance with applicable standards. The serviceability of a product or structure utilizing this type of information is and must be the sole responsibility of the builder/user. Many variables beyond the control of HYUNDAI WELDING CO., LTD. affect the results obtained in applying this type of information. These variables include, but are not limited to, welding procedure, shielding gas, plate chemistry and temperature, weldment design, fabrication methods and service requirements.



Diffusible Hydrogen Content

❖ Welding Conditions

Diameter	: 1.2mm (0.052in)	Amps / Volts	: 280A / 30V
Shielding Gas	: 80%Ar +20%CO ₂	Stick-Out(mm)	: 20~25mm (0.79~0.98in)
Flow Rate	: 20 ℓ /min	Welding Speed	: 30 cm/min (12 in/min)
Welding Position	: 1G (PA)	Current Type & Polarity	: DC(+)

❖ Hydrogen Analysis Using Gas Chromatography Method

Hydrogen Evolution Time	: 72 hrs
Evolution Temp.	: 45 °C (113°F)
Barometric Pressure	: 780 mm-Hg

❖ Result(ml/100g Weld Metal)

X1	X2	X3	X4
3.3	3.3	3.6	3.2

Average Hydrogen Content 3.4 ml / 100g Weld Metal



Diffusible Hydrogen Content

❖ Welding Conditions

Diameter	: 1.2mm (0.052in)	Amps / Volts	: 280A / 30V
Shielding Gas	: 90%Ar +10%CO ₂	Stick-Out(mm)	: 20~25mm (0.79~0.98in)
Flow Rate	: 20 ℓ /min	Welding Speed	: 30 cm/min (12 in/min)
Welding Position	: 1G (PA)	Current Type & Polarity	: DC(+)

❖ Hydrogen Analysis Using Gas Chromatography Method

Hydrogen Evolution Time	: 72 hrs
Evolution Temp.	: 45 °C (113°F)
Barometric Pressure	: 780 mm-Hg

❖ Result(ml/100g Weld Metal)

X1	X2	X3	X4
3.8	3.7	3.8	3.3

Average Hydrogen Content 3.7 ml / 100g Weld Metal



Welding Efficiency

❖ Deposition Rate & Efficiency

Wire Size	Welding Conditions		Wire Feed Speed m/min (in/min)	Deposition Efficiency (%)	Deposition Rate kg/hr (lb/hr)
	Amp. (A)	Volt. (V)			
1.2mm (0.045in)	220	27~28	6.6(260)	93~95	3.3(7.2)
	280	29~30	9.2(360)	94~96	4.8(10.5)
	350	33~34	13.0(510)	95~98	6.5(14.3)
Remark				Deposition efficiency =(Deposited metal weight/ Wire weight used)×100	Deposition rate =(Deposited metal weight/ Welding time,min.)×60

* Shielding Gas : 80%Ar+20%CO₂

* Shielding Gas : 90%Ar+10%CO₂



Proper Welding Condition

❖ Welding Conditions

Consumable	Shielding Gas	Welding Position	Wire Dia.
			1.2mm (0.045in)
SC-80ML	80%Ar + 20%CO ₂ / 90%Ar + 10%CO ₂	F & HF	200~300Amp

❖ F No & A No

F No	A No
6	10

This information is provided solely for the purpose of confirming product conformance with applicable standards. The serviceability of a product or structure utilizing this type of information is and must be the sole responsibility of the builder/user. Many variables beyond the control of HYUNDAI WELDING CO., LTD. affect the results obtained in applying this type of information. These variables include, but are not limited to, welding procedure, shielding gas, plate chemistry and temperature, weldment design, fabrication methods and service requirements.